

# Langdrehwerkzeuge

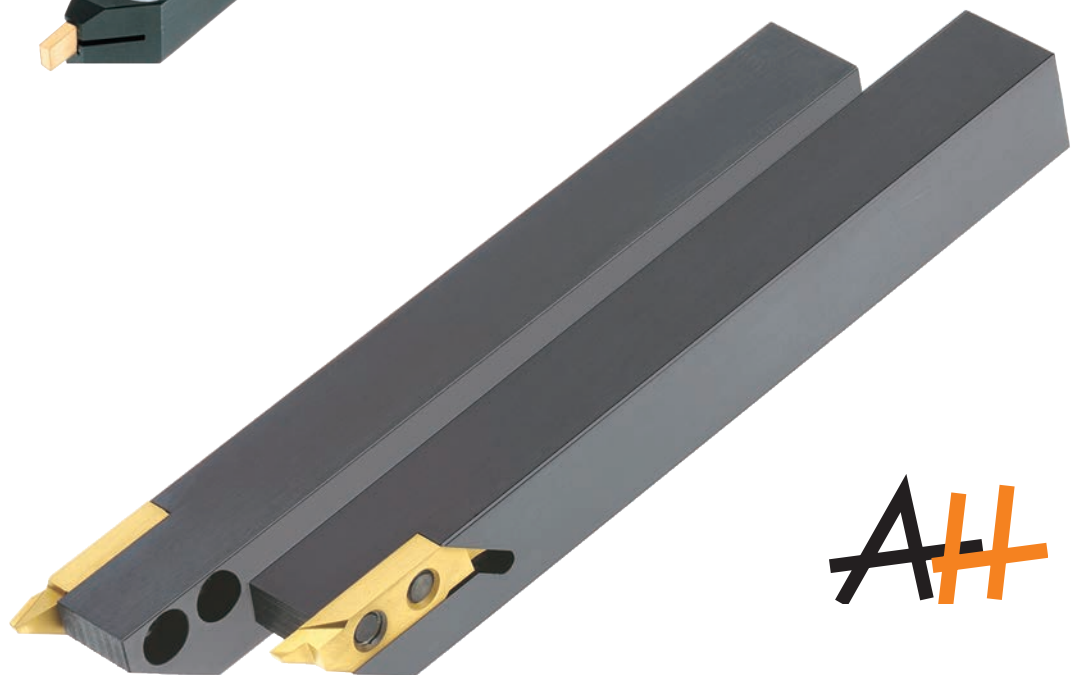

Deco



## Langdrehwerkzeuge

Deco Automaten-Halter 05 .....	01E-3
Deco Drehklingen 05 .....	01E-4
Deco Stechklingen 05 .....	01E-4
Deco Automaten-Halter 08 .....	01E-5
Deco Drehklingen 08 .....	01E-6
Deco Stechklingen 08 .....	01E-6
Drehhalter SVJC.....	01E-7
Drehwendeplatten VC... ..	01E-8
Drehhalter SDJ... ..	01E-9
Drehwendeplatten DC... ..	01E-10
Langdrehhalter AHLD.....	01E-11
Langdrehwendeplatten AWLD .....	01E-12
Bearbeitungsbeispiele Langdrehen.....	01E-13

Andere Ausführungen und Abmessungen auf Anfrage.

Konstruktionsänderungen vorbehalten.

Alle Preise in Euro (€), zuzüglich Mehrwertsteuer.

## Deco Automaten-Halter 05 zum Längs- und Einstechdrehen

# Deco

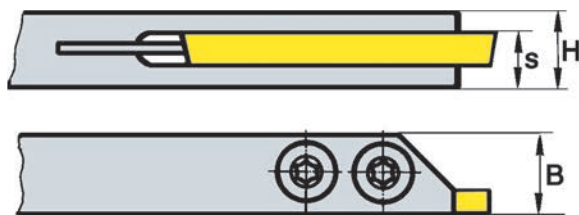

Links = L

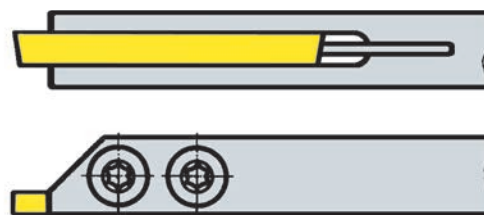

Rechts = R

Warengruppe 01E

Bestellnummer	Abmessungen in mm				Dis	Preis €/ Stück
	B	H	L	s		
AH 08 x 08 110 L	8	8	110	6,5	★	96,80
AH 08 x 08 110 R	8	8	110	6,5	★	96,80
AH 10 x 10 120 L	10	10	120	7,5	★	101,60
AH 10 x 10 120 R	10	10	120	7,5	★	101,60
AH 12 x 12 120 L	12	12	120	8,5	★	101,60
AH 12 x 12 120 R	12	12	120	8,5	★	101,60
AH 14 x 14 120 L	14	14	120	10,5	☆	121,00
AH 14 x 14 120 R	14	14	120	10,5	☆	121,00

Passende Klingen siehe Seite 01E-4.

Warengruppe 21

Ersatzteile	Schraube	€/ Stück	Schraubendreher	€/ Stück
für AH08 x 08	SCHT10 M3 x 7,5	4,90	SDTG 10	9,80
für AH10 x 10	SCHT20 M4 x 9,5	4,90	SDTG 20	9,80
für AH12 x 12 / 14 x 14	SCHT25 M5 x 11,5	4,90	SDTG 25	9,80

★ = ab Lager

☆ = kurzfristig lieferbar

☐ = auf Anfrage

l <sub>1</sub> ISO - Code Länge	E	F	G	H	J	K	L	M	N	P	Q	R	S	T	X
l <sub>1</sub> Länge in mm	70	80	90	100	110	125	140	150	160	170	180	200	250	300	Spezial

### Deco Drehklingen 05

# Deco

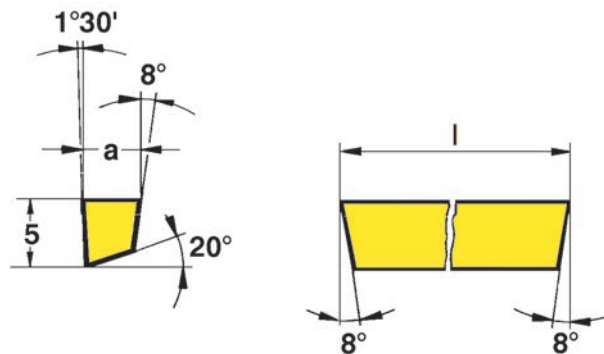

Warengruppe 01F

Bestellnummer	Abmessungen in mm		unbeschichtet		Preis €/ Stück	beschichtet		Preis €/ Stück
	l	a		K10		A310	A410	
D 2,5	40	2,5		☆	28,00	☆	☆	34,90
D 3,0	40	3,0		☆	28,00	☆	☆	34,90
D 4,0	40	4,0		☆	34,80	☆	☆	41,70

Passende Halter AH... siehe Seite 01E-3.

### Deco Stechklingen 05

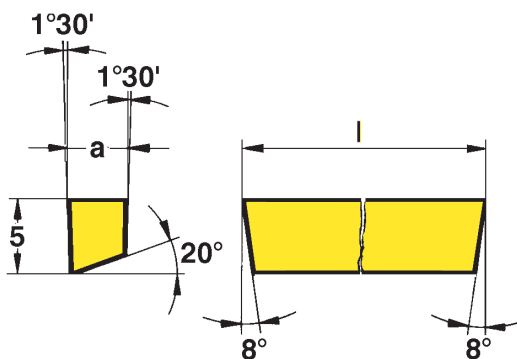

Warengruppe 01F

Bestellnummer	Abmessungen in mm		unbeschichtet		Preis €/ Stück	beschichtet		Preis €/ Stück
	l	a		K10		A310	A410	
S 1,0	40	1,0		☆	28,00	☆	☆	34,90
S 1,5	40	1,5		☆	28,00	☆	☆	34,90
S 2,0	40	2,0		☆	28,00	☆	☆	34,90
S 2,5	40	2,5		☆	28,00	☆	☆	34,90
S 3,0	40	3,0		☆	28,00	☆	☆	34,90
S 4,0	40	4,0		☆	34,80	☆	☆	41,80

Passende Halter Deco AH... siehe Seite 01E-3.

★ = ab Lager

☆ = kurzfristig lieferbar

□ = auf Anfrage

## Deco Automaten-Halter 08 zum Längs- und Einstechdrehen

# Deco

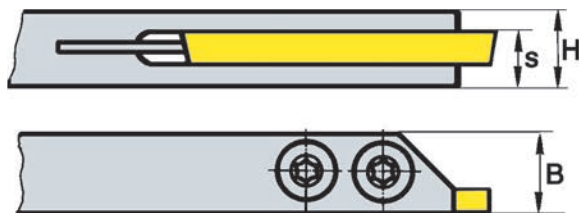

Links = L

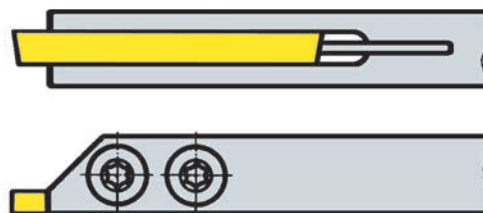

Rechts = R

Warengruppe 01E

Bestellnummer	Abmessungen in mm				Dis	Preis €/ Stück
	B	H	L	s		
AH 16 x 16 140 L 08	16	16	140	12,5	★	121,00
AH 16 x 16 140 R 08	16	16	140	12,5	★	121,00
AH 20 x 20 140 L 08	20	20	140	16,0	★	125,40
AH 20 x 20 140 R 08	20	20	140	16,0	★	125,40

Passende Klingen siehe Seite 01E-6.

Warengruppe 21

Ersatzteile	Schraube	€/ Stück	Schraubendreher	€/ Stück
für AH16 x 16	SCHT25 M5 x 15	4,90	SDTG 25	9,80
für AH20 x 20	SCHT30 M6 x 16	4,90	SDTG 30	9,80

★ = ab Lager

☆ = kurzfristig lieferbar

☐ = auf Anfrage

l <sub>1</sub> ISO - Code Länge	E	F	G	H	J	K	L	M	N	P	Q	R	S	T	X
l <sub>1</sub> Länge in mm	70	80	90	100	110	125	140	150	160	170	180	200	250	300	Spezial

### Deco Drehklingen 08

# Deco

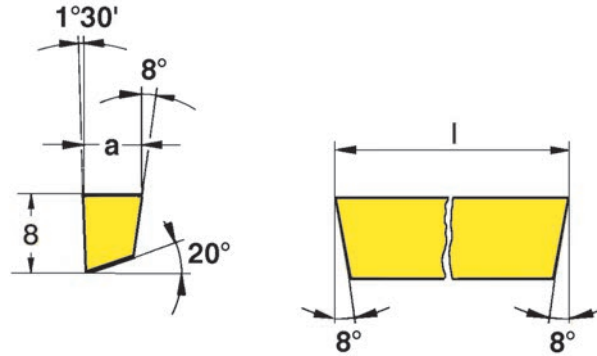

Warengruppe 01F

Bestellnummer	Abmessungen in mm		unbeschichtet		Preis €/ Stück	beschichtet		Preis €/ Stück
	l	a		K10UF		A310	A410	
D 4,0 08	50	4,0		★	41,50	☆	☆	48,40

Passende Halter AH...08 siehe Seite 01E-5.

### Deco Stechklingen 08

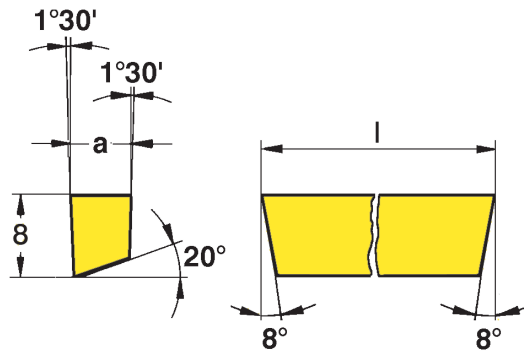

Warengruppe 01F

Bestellnummer	Abmessungen in mm		unbeschichtet		Preis €/ Stück	beschichtet		Preis €/ Stück
	l	a		K10UF		A310	A410	
S 1,5 08	50	1,5		★	41,50	☆	☆	48,40
S 2,0 08	50	2,0		★	41,50	☆	☆	48,40
S 3,0 08	50	3,0		★	44,20	☆	☆	51,10
S 4,0 08	50	4,0		★	44,20	☆	☆	51,10

Passende Halter AH...08 siehe Seite 01E-5.

★ = ab Lager

☆ = kurzfristig lieferbar

☐ = auf Anfrage

### Drehhalter SVJC...

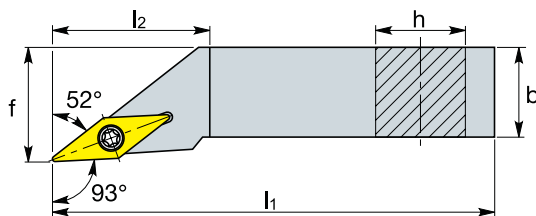
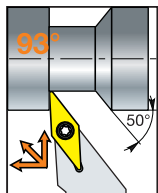

Warengruppe 05A

Bestellnummer				Abmessungen in mm				Wendeschneidplatte	Torxschraube	Schraubendreher	Preis €/Stück	Dis		
h	b	l <sub>1</sub>		l <sub>2</sub>	f		L					N	R	
SVJCR /L	12	12	N	13	27	16	VC...13	SCHT09 M3 x 06	SDTG 09	9,80 EUR	<input type="checkbox"/>	<input type="checkbox"/>	<input type="checkbox"/>	
SVJCR/L	16	16	H	13	27	20					<input type="checkbox"/>	<input type="checkbox"/>	<input type="checkbox"/>	

Passende Wendeschneidplatten siehe Seite 01E-8.

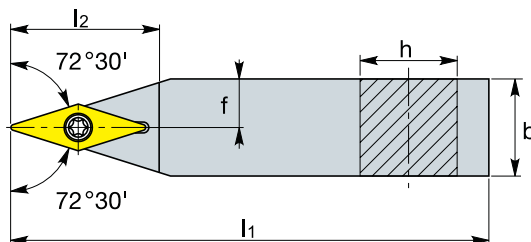
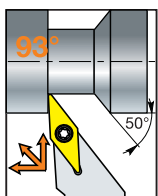

Warengruppe 05A

Bestellnummer				Abmessungen in mm				Wendeschneidplatte	Torxschraube	Schraubendreher	Preis €/Stück	Dis		
h	b	l <sub>1</sub>		l <sub>2</sub>	f		L					N	R	
SVVCN	12	12	N	13	27	6	VC...13	SCHT09 M3 x 06	SDTG 06	9,80 EUR	<input type="checkbox"/>	<input type="checkbox"/>	<input type="checkbox"/>	
SVVCN	16	16	H	13	30	8					<input type="checkbox"/>	<input type="checkbox"/>	<input type="checkbox"/>	

Passende Wendeschneidplatten siehe Seite 01E-8.

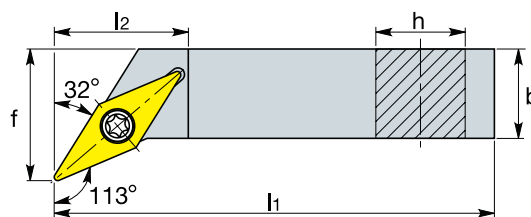
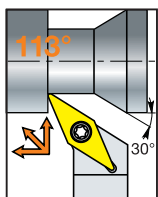

Warengruppe 05A

Bestellnummer				Abmessungen in mm				Wendeschneidplatte	Torxschraube	Schraubendreher	Unterlag- platte	Preis €/Stück	Dis		
h	b	l <sub>1</sub>		l <sub>2</sub>	f		L						N	R	
SVGCR/L	12	12	M	07	18	12,5	VC...07	SCHT06 M2 x 03	SDTG 06	9,80 EUR	<input type="checkbox"/>	<input type="checkbox"/>	<input type="checkbox"/>		
SVGCR/L	16	16	P	07	23	16,3					<input type="checkbox"/>	<input type="checkbox"/>	<input type="checkbox"/>		

Passende Wendeschneidplatten siehe Seite 01E-8.

★ = ab Lager

☆ = kurzfristig lieferbar

= auf Anfrage

l <sub>1</sub> ISO - Code Länge	E	F	G	H	J	K	L	M	N	P	Q	R	S	T	X
l <sub>1</sub> Länge in mm	70	80	90	100	110	125	140	150	160	170	180	200	250	300	Spezial

## Drehwendeplatten VC...

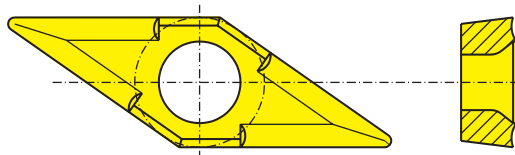

Warengruppe 05B

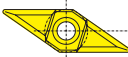
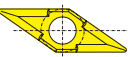
Bestellnummer	Abmessungen in mm			Preise in Euro € / Stück											Passende Wendeplatten				
				beschichtet						unbeschichtet									
				l	s	m		A310	A410	A510	K10								
VCGT 130302- 21	13,84	3,18	8,767	<input type="checkbox"/>		<input type="checkbox"/>		<input type="checkbox"/>		<input type="checkbox"/>									
VCGT 130304- 21	13,84	3,18	8,301	<input type="checkbox"/>		<input type="checkbox"/>		<input type="checkbox"/>		<input type="checkbox"/>				-					
VCGT 130308- 21	13,84	3,18	7,372	<input type="checkbox"/>		<input type="checkbox"/>		<input type="checkbox"/>		<input type="checkbox"/>									
VCGT 130302- 22	13,84	3,18	8,767	<input type="checkbox"/>		<input type="checkbox"/>		<input type="checkbox"/>		<input type="checkbox"/>				-					
VCGT 130304- 22	13,84	3,18	8,301	<input type="checkbox"/>		<input type="checkbox"/>		<input type="checkbox"/>		<input type="checkbox"/>				-					
VCGT 130308- 22	13,84	3,18	7,372	<input type="checkbox"/>		<input type="checkbox"/>		<input type="checkbox"/>		<input type="checkbox"/>									

Passende Halter siehe Seite 01E-7. Passende ISO-Bohrstangen Produktinformation 02B.

★ = ab Lager

☆ = kurzfristig lieferbar

= auf Anfrage



### Drehhalter SDJ...

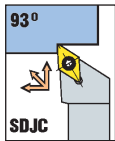

Warengruppe 05A

Bestellnummer				Abmessungen in mm				Wendeplatte	Torxschraube	Schraubendreher	Dis			Preis €/ Stück
h	b	l <sub>1</sub>		l <sub>2</sub>	f		L				N	R		
SDJCR/L	10	10	H 07	17	12			SCHAT07 M2,2 x 08 	SDTG 07  9,80 EUR	<input type="checkbox"/>	<input type="checkbox"/>	<input type="checkbox"/>		
SDJCR/L	12	12	F 07	17	16					<input type="checkbox"/>	<input type="checkbox"/>	<input type="checkbox"/>		
SDJCR/L	16	16	F 07	17	20					<input type="checkbox"/>	<input type="checkbox"/>	<input type="checkbox"/>		
Passende Wendschneidplatten siehe Seite 01E-10.														

★ = ab Lager

☆ = kurzfristig lieferbar

= auf Anfrage

l <sub>1</sub> ISO - Code Länge	E	F	G	H	J	K	L	M	N	P	Q	R	S	T	X
l <sub>1</sub> Länge in mm	70	80	90	100	110	125	140	150	160	170	180	200	250	300	Spezial

### Drehwendeplatten DC...

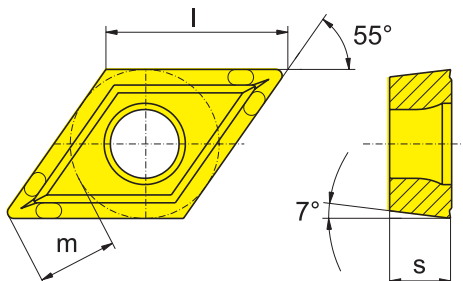

Warengruppe 05B

Bestellnummer	Abmessungen in mm			Preise in Euro € / Stück												Passende Wendeplatten			
				beschichtet						unbeschichtet									
					M920		S920				M20		P20						
DCMT 070202 W3 WA	7,7	2,38	3,464	<input type="checkbox"/>								<input type="checkbox"/>							
DCMT 070204 W3 WA	7,7	2,38	3,238	<input type="checkbox"/>			-					<input type="checkbox"/>			-				
DCMT 070208 W3 WA	7,7	2,38	2,768	<input type="checkbox"/>								<input type="checkbox"/>							

Passende Halter siehe Seite 01E-9. Passende ISO-Bohrstangen Produktinformation 02B.

Warengruppe 05B

Bestellnummer	Abmessungen in mm			Preise in Euro € / Stück												Passende Wendeplatten			
				beschichtet						unbeschichtet									
					S415		S425												
DCMT 070202 B3 Y	7,7	2,38	3,464	<input type="checkbox"/>		<input type="checkbox"/>													
DCMT 070204 B3 Y	7,7	2,38	3,238	<input type="checkbox"/>		<input type="checkbox"/>													
DCMT 070208 B3 Y	7,7	2,38	2,768	<input type="checkbox"/>		<input type="checkbox"/>													

Passende Halter siehe Seite 01E-9. Passende ISO-Bohrstangen Produktinformation 02B.

★ = ab Lager







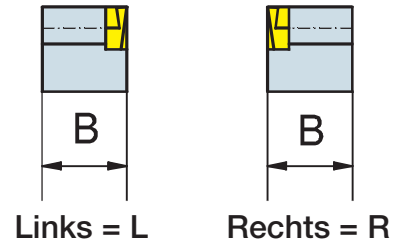
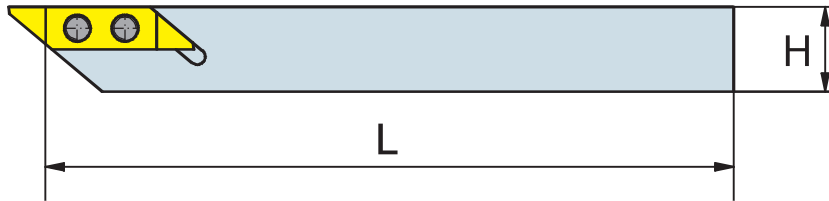

☆ = kurzfristig lieferbar

= auf Anfrage

## Langdrehhalter AHLD



Warengruppe 01M

Bestellnummer				Abmessungen in mm				Wendeplatte	Schraube	Schraubendreher	Dis			Preis €/ Stück
H	B	L		H	B	L	L					R		
AHLD	10	10	130	R	10	10	130		 SCHT20 M5x9  3,80 EUR	 SDTF20 4,50 EUR			☆	65,00
AHLD	12	12	130	R	12	12	130						☆	65,00
AHLD	10	10	130	L	10	10	130				☆			65,00
AHLD	12	12	130	L	12	12	130				☆			65,00
AHLD	16	16	130	R	16	16	130		 SCHT20 M5x12  3,80 EUR	 SDTF20 4,50 EUR			☆	77,00
AHLD	20	20	130	R	20	20	130						☆	77,00
AHLD	16	16	130	L	16	16	130				☆			77,00
AHLD	20	20	130	L	20	20	130				☐			

Passende Wendeschneidplatten siehe Seite 01E-12.

★ = ab Lager

☆ = kurzfristig lieferbar

☐ = auf Anfrage

### Langdrehwendeplatten AWLD

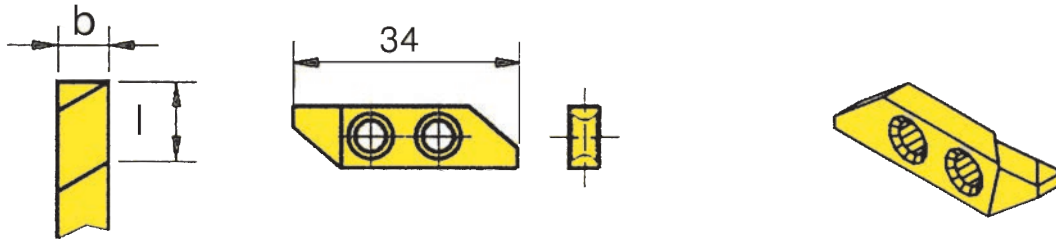

Warengruppe 01N

Bestellnummer	Abmessungen in mm			Preise in Euro € / Stück										Passende Wendeplatten
				beschichtet					unbeschichtet					
	b	l	a	A310	A410				K10F					
<b>Abstechen / Drehen</b>														
AWLD 1,0 R/L AD	1,0	2,5		☆	28,60	☆	30,30			☆	25,30			
AWLD 1,5 R/L AD	1,5	3,0		☆	26,60	☆	28,30			☆	23,30			
AWLD 2,0 R/L AD	2,0	4,0		☆	26,60	☆	28,30			☆	23,30			
AWLD 2,5 R/L AD	2,5	5,0		☆	26,60	☆	28,30			☆	23,30			
AWLD 3,0 R/L AD	3,0	6,0		☆	26,60	☆	28,30			☆	23,30			
<b>Einstechen / Drehen</b>														
AWLD 3,0-1,6 R/L ED	3,0	3,8	1,6	☆	26,60	☆	28,30			☆	23,30			
AWLD 3,5-1,6 R/L ED	6,8	5,0	1,6	☆	26,60	☆	28,30			☆	23,30			
AWLD 4,0-1,6 R/L ED	4,0	3,8	1,6	☆	26,60	☆	28,30			☆	23,30			
<b>Abstechen</b>														
AWLD 1,0 R/L AS	1,0	5,5		☆	23,30	☆	25,20			☆	20,20			
AWLD 1,5 R/L AS	1,5	6,5		☆	23,30	☆	25,20			☆	20,20			
AWLD 2,0 R/L AS	2,0	8,5		☆	23,30	☆	25,20			☆	20,20			
AWLD 2,5 R/L AS	2,5	8,5		☆		☆	25,20			☆	20,20			
<b>Einstechen - Formstechen (für Gewindefreistich)</b>														
AWLD 1,5 R/L FS	1,5	4,0		<input type="checkbox"/>		<input type="checkbox"/>								
AWLD 2,0 R/L FS	2,0	5,0		<input type="checkbox"/>		<input type="checkbox"/>								
AWLD 2,5 R/L FS	2,5	5,0		<input type="checkbox"/>		<input type="checkbox"/>								
Passende Halter siehe Seite 01E-11. Andere Formen und Profile auf Anfrage.														

★ = ab Lager

☆ = kurzfristig lieferbar

= auf Anfrage

### Bearbeitungsbeispiele Langdrehen

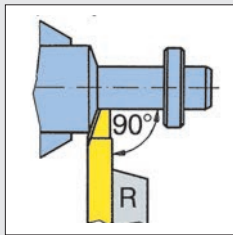

**Einstecken  
Drehen**

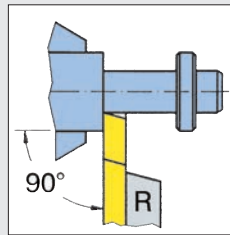

**Drehen  
Abstechen**

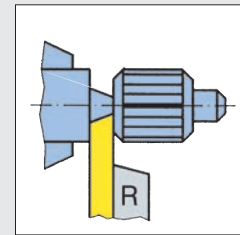

**Abstechen**

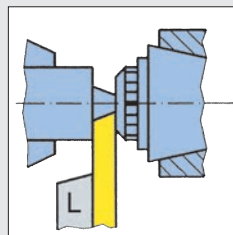

**Abstechen**

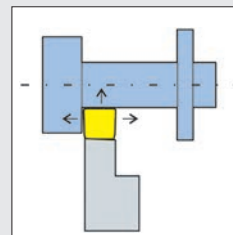

**Auskammern**

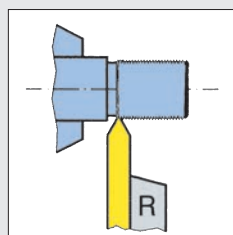

**Gewinde  
Teilprofil**

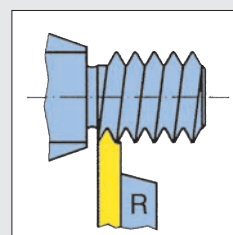

**Gewinde  
Vollprofil**

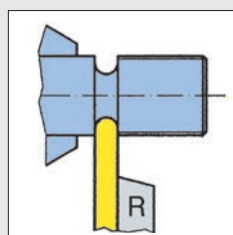

**Formstechen**

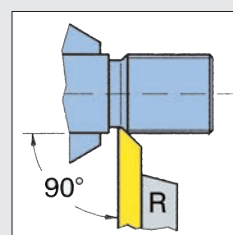

Weitere Werkzeuge; Logos

**Deco**

**Fix-Profil**

Flachformwerkzeuge

Langdrehhalter  
mit Wendepplatten  
für Drehautomaten

**AH**

**Quattro**

Stechklinge mit 4 Schneiden

Endenbearbeitungswerkzeuge

**SIX CUT**

**M-System**

Abstechdrehen auf  
Mehrspindel-Automaten