

Vollbohrer

Silber-Drill

Gold-Drill



Vollbohrer VBAS..

Gold-Drill Vollbohrer VBAS... ..	06A-3
Gold-Drill Bohreinsätze VBES A bis E C3 (Stahl und Guss)	06A-4
Gold-Drill Bohreinsätze VBES F bis H C3 (Stahl und Guss)	06A-5
Technische Informationen Gold-Drill	06A-6
Silber-Drill Vollbohrer VBSD 12,0 bis 16,0 mm	06A-7
Silber-Drill Vollbohrer VBSD 16,5 bis 21,0 mm	06A-8
Silber-Drill Vollbohrer VBSD 22,0 bis 30,0 mm	06A-9
Technische Informationen Silber-Drill	06A-10
Silber-Drill Bohreinsätze BESD	06A-11
Anwendungsbeispiele	06A-12

Andere Ausführungen und Abmessungen auf Anfrage.

Konstruktionsänderungen vorbehalten.

Alle Preise in Euro (€), zuzüglich Mehrwertsteuer.

Gold-Drill Vollbohrer VBAS...

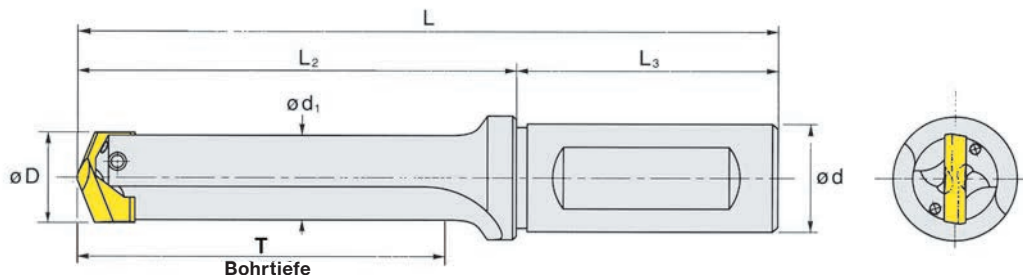
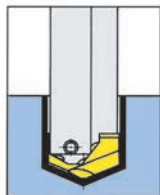

Warengruppe 06A

Bestellnummer	Abmessungen in mm							Bohr-einsätze	Dis	
	D	d	₁	L	T	L ₂	L ₃			
VBAS 13,0-15,0 A T45	12,7 - 15,0	20	12,5	110	45	70	40	A	★	
VBAS 13,0-15,0 A T75	12,7 - 15,0	20	12,5	140	75	100	40	A	★	
VBAS 13,0-15,0 A T120	12,7 - 15,0	20	12,5	185	120	145	40	A	★	
VBAS 15,0-17,0 B T50	14,8 - 17,0	20	14,5	116	50	76	40	B	★	
VBAS 15,0-17,0 B T85	14,8 - 17,0	20	14,5	150	85	110	40	B	★	
VBAS 15,0-17,0 B T135	14,8 - 17,0	20	14,5	200	135	160	40	B	★	
VBAS 17,0-19,0 C T60	16,5 - 19,0	20	16,0	122	60	82	40	C	★	
VBAS 17,0-19,0 C T95	16,5 - 19,0	20	16,0	160	95	120	40	C	★	
VBAS 17,0-19,0 C T150	16,5 - 19,0	20	16,0	215	150	175	40	C	★	
VBAS 19,0-21,0 D T65	18,5 - 21,0	20	18,0	128	65	88	40	D	★	
VBAS 19,0-21,0 D T105	18,5 - 21,0	20	18,0	170	105	130	40	D	★	
VBAS 19,0-21,0 D T165	18,5 - 21,0	20	18,0	230	165	190	40	D	★	
VBAS 21,0-23,0 E T70	20,5 - 23,0	25	20,0	148	70	93	55	E	★	
VBAS 21,0-23,0 E T115	20,5 - 23,0	25	20,0	195	115	140	55	E	★	
VBAS 21,0-23,0 E T185	20,5 - 23,0	25	20,0	265	185	210	55	E	★	
VBAS 23,0-26,0 F T80	22,5 - 26,0	25	22,0	157	80	102	55	F	★	
VBAS 23,0-26,0 F T130	22,5 - 26,0	25	22,0	210	130	155	55	F	★	
VBAS 23,0-26,0 F T210	22,5 - 26,0	25	22,0	290	210	235	55	F	★	
VBAS 26,1-29,0 G T90	26,1-29,0	32	25	183	90	123	60	G	★	
VBAS 26,1-29,0 G T145	26,1-29,0	32	25	238	145	178	60	G	★	
VBAS 28,5-35,0 H T105	28,5-35,0	32	28	198	105	138	60	H	★	
VBAS 28,5-35,0 H T175	28,5-35,0	32	28	268	175	208	60	H	★	

Preise ohne Einsatz. Passende Bohreinsätze VBE... siehe Seite 06A-4 bis 06A-5

Warengruppe 21

Ersatzteile	Schraube	Schraubendreher/Schlüssel
VBAS... A	SCHW M 3x6 DIN914 SY	SDIG 3,0
VBAS... B bis C	SCHW M 3x8 DIN914 SY	SDIG 3,0
VBAS... D	SCHW M 4x8 DIN914 SY	SDIG 4,0
VBAS... E bis F	SCHW M 4x10 DIN914 SY	SDIG 4,0
VBAS... G bis H	SCHW M 5x12 DIN914 SY	SDIG 5,0

★ = ab Lager

☆ = kurzfristig lieferbar

☐ = auf Anfrage

Gold-Drill Bohreinsätze VBES A bis E C3 (Stahl und Guss)

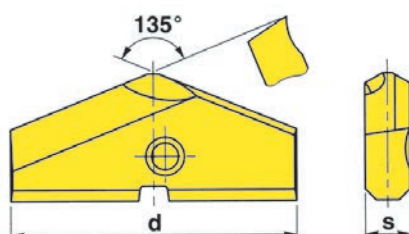

Warengruppe 06B

Bestellnummer	Abmessungen in mm		Vollbohrer Typ		
	d	s			A410
VBES 12,7 A C3	12,7	4,0	A		★
VBES 13,0 A C3	13,0	4,0	A		★
VBES 13,5 A C3	13,5	4,0	A		★
VBES 14,0 A C3	14,0	4,0	A		★
VBES 14,5 A C3	14,5	4,0	A		★
VBES 15,0 A C3	15,0	4,0	A		★
VBES 15,5 B C3	15,5	4,0	B		★
VBES 16,0 B C3	16,0	4,0	B		★
VBES 16,5 B C3	16,5	4,0	B		★
VBES 17,0 B C3	17,0	4,0	B		★
VBES 17,5 C C3	17,5	4,0	C		★
VBES 18,0 C C3	18,0	4,0	C		★
VBES 18,5 C C3	18,5	4,0	C		★
VBES 19,0 C C3	19,0	4,0	C		★
VBES 19,5 D C3	19,5	4,0	D		★
VBES 20,0 D C3	20,0	4,0	D		★
VBES 20,5 D C3	20,5	4,0	D		★
VBES 21,0 D C3	21,0	4,0	D		★
VBES 21,5 E C3	21,5	4,0	E		★
VBES 22,0 E C3	22,0	4,0	E		★
VBES 22,5 E C3	22,5	4,0	E		★
VBES 23,0 E C3	23,0	4,0	E		★
Passende Vollbohrer VBAS... siehe Seite 06A-3.					

★ = ab Lager

☆ = kurzfristig lieferbar

☐ = auf Anfrage

Gold-Drill Bohreinsätze VBES F bis H C3 (Stahl und Guss)

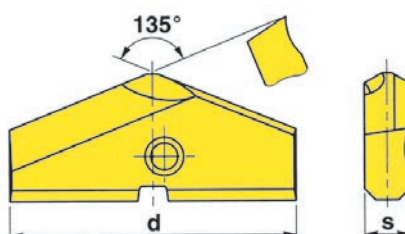

Warengruppe 06B

Bestellnummer	Abmessungen in mm		Vollbohrer Typ		
	d	s			A410
VBES 23,5 F C3	23,5	4,0	F		★
VBES 24,0 F C3	24,0	4,0	F		★
VBES 24,5 F C3	24,5	4,0	F		★
VBES 25,0 F C3	25,0	4,0	F		★
VBES 25,5 F C3	25,5	4,0	F		★
VBES 26,0 F C3	26,0	4,0	F		★
VBES 26,5 G C3	26,5	5,0	G		★
VBES 27,0 G C3	27,0	5,0	G		★
VBES 27,5 G C3	27,5	5,0	G		★
VBES 28,0 G C3	28,0	5,0	G		★
VBES 28,5 G C3	28,5	5,0	G		★
VBES 29,0 G C3	29,0	5,0	G		★
VBES 29,5 H C3	29,5	5,0	H		★
VBES 30,0 H C3	30,0	5,0	H		★
VBES 30,5 H C3	30,5	5,0	H		★
VBES 31,0 H C3	31,0	5,0	H		★
VBES 31,5 H C3	31,5	5,0	H		★
VBES 32,0 H C3	32,0	5,0	H		★
VBES 32,5 H C3	32,5	5,0	H		★
VBES 33,0 H C3	33,0	5,0	H		★
VBES 33,5 H C3	33,5	5,0	H		★
VBES 34,0 H C3	34,0	5,0	H		★
VBES 34,5 H C3	34,5	5,0	H		★
VBES 35,0 H C3	35,0	5,0	H		★
Passende Vollbohrer VBAS... siehe Seite 06A-3.					

★ = ab Lager

☆ = kurzfristig lieferbar

☐ = auf Anfrage

Technische Informationen Gold-Drill

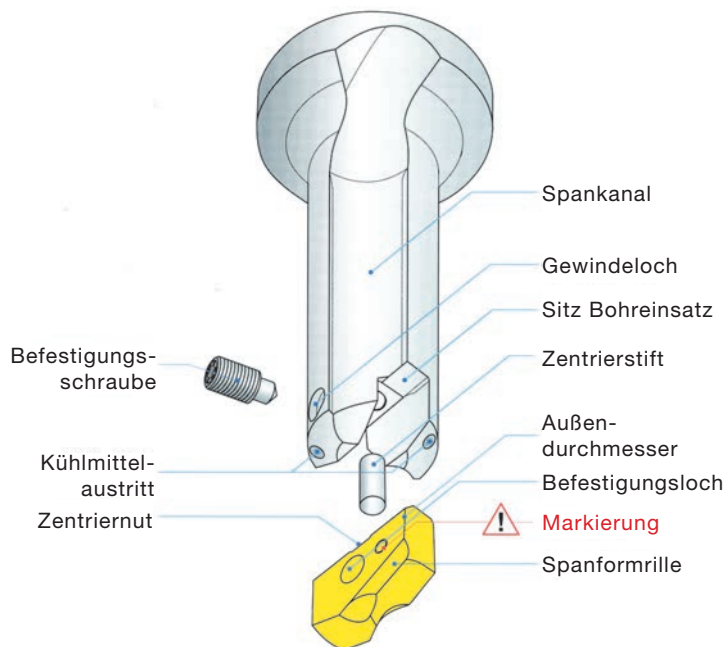
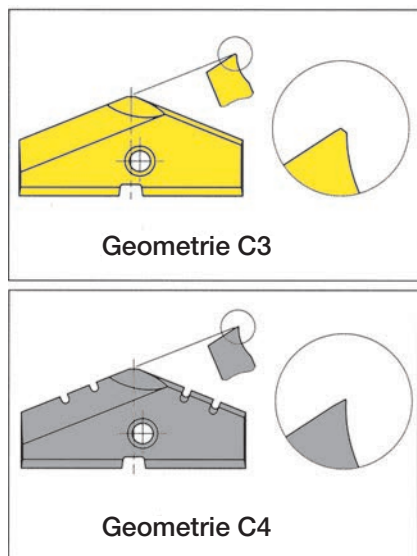

Schnittwerte								
Material	Festigkeit Rm (N/mm ²)	Härte	Sorte	Geometrie	VC (m/min)	Vorschub (mm/U)		
						Ø 12,7 - 16,7	Ø 16,7 - 22,0	Ø 22 - 35
Stähle								
Kohlenstoff < 0.2%	310-580	65	A410	C3	60-120	0,05 - 0,15	0,08 - 0,20	0,15 - 0,25
Kohlenstoff < 0.35%	340-680	65	A410	C3	55-110	0,05 - 0,13	0,08 - 0,18	0,15 - 0,20
Kohlenstoff 0.4%	520-930	65	A410	C3	50-100	0,05 - 0,13	0,08 - 0,18	0,15 - 0,20
Niedriglegiert, gehärtet und vergütet	310-840	65	A410	C3	40-70	0,05 - 0,13	0,08 - 0,18	0,15 - 0,20
Niedriglegiert, gehärtet und vergütet	745-1360	65	A410	C3	30-60	0,05 - 0,13	0,08 - 0,18	0,12 - 0,20
Hochlegiert, gegläht	310-840	65	A410	C3	40-70	0,05 - 0,13	0,08 - 0,18	0,15 - 0,20
Hochlegierte Stähle, gehärtet und vergütet	840-1580	65	A410	C3	30-50	0,05 - 0,08	0,06 - 0,10	0,08 - 0,15
Unlegierter Stahlguß	340-760	65	A410	C3	50-80	0,05 - 0,13	0,08 - 0,20	0,12 - 0,25
Niederlegierter Stahlguß	520-745	65	A410	C3	45-70	0,05 - 0,11	0,08 - 0,15	0,10 - 0,20
Hochlegierter Stahlguß	600-775	65	A410	C3	40-60	0,05 - 0,08	0,06 - 0,10	0,08 - 0,15
Rostfreie Stähle								
Geglüht, martensitisch, ferritisch	-	65	A410	C3	40-90	0,05 - 0,13	0,08 - 0,18	0,12 - 0,20
Geglüht, austenitisch	-	65	A410	C3	40-80	0,05 - 0,13	0,08 - 0,18	0,12 - 0,20
Guss								
Temperguß	-	65	A410	C3	70-100	0,08 - 0,20	0,10 - 0,25	0,15 - 0,25
Pearlitischer Temperguß	-	65	A410	C3	60-90	0,08 - 0,15	0,10 - 0,20	0,15 - 0,20
Grauguss (FG)	-	65	A410	C3	80-110	0,08 - 0,20	0,10 - 0,25	0,15 - 0,25
Grauguss (FG)	-	65	A410	C3	60-90	0,08 - 0,15	0,10 - 0,20	0,15 - 0,20
Kugelgraphitguß GS, ferritisch	-	65	A410	C3	70-100	0,08 - 0,20	0,10 - 0,25	0,15 - 0,25
Kugelgraphitguß GS, perlitisch	-	65	A410	C3	60-90	0,08 - 0,15	0,10 - 0,20	0,15 - 0,20
Andere Legierungen								
Aluminiumlegierungen <6% Si	-	15	K10F	C4	100-250	0,05 - 0,20	0,08 - 0,25	0,10 - 0,30
Aluminiumlegierungen 13% Si	-	15	K10F	C4	100-250	0,05 - 0,20	0,08 - 0,25	0,10 - 0,30
Messing, Blei	-	15	K10F	C4	120-160	0,05 - 0,20	0,08 - 0,25	0,10 - 0,30

Silber-Drill Vollbohrer VBSD 12,0 bis 16,0 mm

Silber-Drill

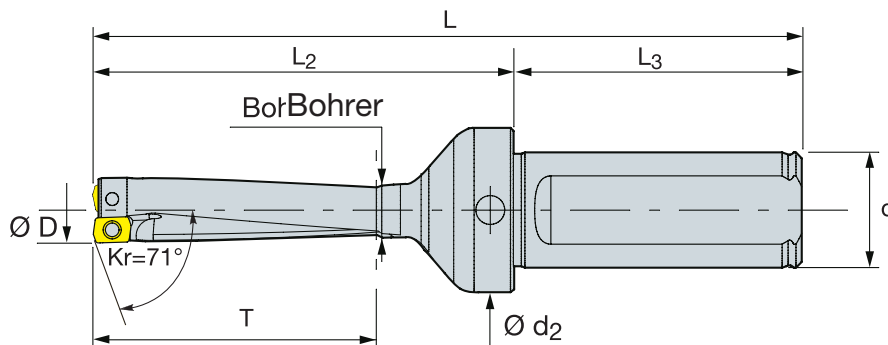

Warengruppe 06H

Bestellnummer	Abmessungen in mm								Bohreinsätze	Dis
	D	d	d ₂	L	T	L ₂	L ₃	kg		
VBSD 12,0 04 T24	12,0	20	28,5	98	24	48	50	0,175	BESD 04...	★
VBSD 12,0 04 T48	12,0	20	28,5	122	48	72	50	0,185	BESD 04...	★
VBSD 12,5 04 T25	12,5	20	28,5	98	25	48	50	0,175	BESD 04...	★
VBSD 12,5 04 T50	12,5	20	28,5	123	50	73	50	0,185	BESD 04...	★
VBSD 13,0 04 T26	13,0	20	28,5	99	26	49	50	0,175	BESD 04...	★
VBSD 13,0 04 T52	13,0	20	28,5	125	52	75	50	0,185	BESD 04...	★
VBSD 13,5 04 T27	13,5	20	28,5	100	27	50	50	0,180	BESD 04...	★
VBSD 13,5 04 T54	13,5	20	28,5	127	54	77	50	0,190	BESD 04...	★
VBSD 14,0 04 T28	14,0	20	28,5	101	28	51	50	0,180	BESD 04...	★
VBSD 14,0 04 T56	14,0	20	28,5	129	56	79	50	0,195	BESD 04...	★
VBSD 14,5 04 T29	14,5	20	28,5	101	29	51	50	0,180	BESD 04...	★
VBSD 14,5 04 T58	14,5	20	28,5	130	58	80	50	0,200	BESD 04...	★
VBSD 15,0 04 T30	15,0	20	28,5	102	30	52	50	0,185	BESD 04...	★
VBSD 15,0 04 T60	15,0	20	28,5	132	60	82	50	0,200	BESD 04...	★
VBSD 15,5 04 T31	15,5	20	28,5	103	31	53	50	0,185	BESD 04...	★
VBSD 15,5 04 T62	15,5	20	28,5	134	62	84	50	0,210	BESD 04...	★
VBSD 16,0 04 T32	16,0	20	28,5	104	32	54	50	0,190	BESD 04...	★
VBSD 16,0 04 T64	16,0	20	28,5	136	64	86	50	0,215	BESD 04...	★

Preise ohne Einsatz. Passende Bohreinsätze BESD siehe Seite 06A-11.

Warengruppe 21

Ersatzteile		
12,0 bis 16,0	SCHT07 M2,2	SDTG 7,0

★ = ab Lager

☆ = kurzfristig lieferbar

□ = auf Anfrage

Silber-Drill Vollbohrer VBSD 16,5 bis 21,0 mm

Silber-Drill

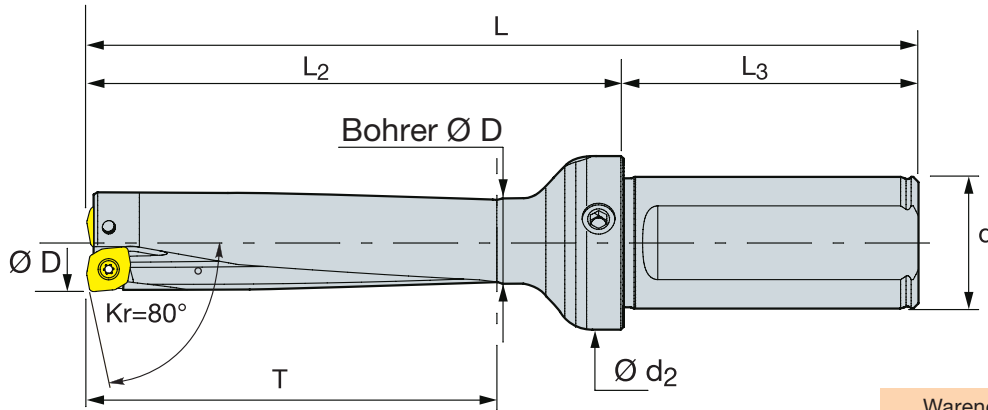

Warengruppe 06H

Bestellnummer	Abmessungen in mm								Bohreinsätze	Dis
	D	d	d ₂	L	T	L ₂	L ₃	kg		
VBSD 16,5 06 T33	16,5	20	28,5	104	33	54	50	0,180	BESD 06...	★
VBSD 16,5 06 T66	16,5	20	28,5	137	66	87	50	0,205	BESD 06...	★
VBSD 17,0 06 T34	17,0	20	28,5	105	34	55	50	0,185	BESD 06...	★
VBSD 17,0 06 T68	17,0	20	28,5	139	68	89	50	0,210	BESD 06...	★
VBSD 17,5 06 T35	17,5	20	28,5	106	35	56	50	0,185	BESD 06...	★
VBSD 17,5 06 T70	17,5	20	28,5	141	70	91	50	0,215	BESD 06...	★
VBSD 18,0 06 T36	18,0	20	28,5	107	36	57	50	0,190	BESD 06...	★
VBSD 18,0 06 T72	18,0	20	28,5	143	72	93	50	0,225	BESD 06...	★
VBSD 18,5 06 T37	18,5	20	28,5	107	37	57	50	0,190	BESD 06...	★
VBSD 18,5 06 T74	18,5	20	28,5	144	74	94	50	0,225	BESD 06...	★
VBSD 19,0 06 T38	19,0	20	28,5	108	38	58	50	0,195	BESD 06...	★
VBSD 19,0 06 T76	19,0	20	28,5	146	76	96	50	0,235	BESD 06...	★
VBSD 20,0 06 T40	20,0	20	28,5	110	40	60	50	0,205	BESD 06...	★
VBSD 20,0 06 T80	20,0	20	28,5	150	80	100	50	0,250	BESD 06...	★
VBSD 21,0 06 T42	21,0	20	28,5	111	42	61	50	0,215	BESD 06...	★
VBSD 21,0 06 T84	21,0	20	28,5	153	84	103	50	0,275	BESD 06...	★

Preise ohne Einsatz. Passende Bohreinsätze BESD siehe Seite 06A-11.

Warengruppe 21

Ersatzteile			
16,5 bis 21,0	SCHT07 M2,2	SDTG 7,0	

★ = ab Lager

☆ = kurzfristig lieferbar

☐ = auf Anfrage

Silber-Drill Vollbohrer VBSD 22,0 bis 30,0 mm

Silber-Drill

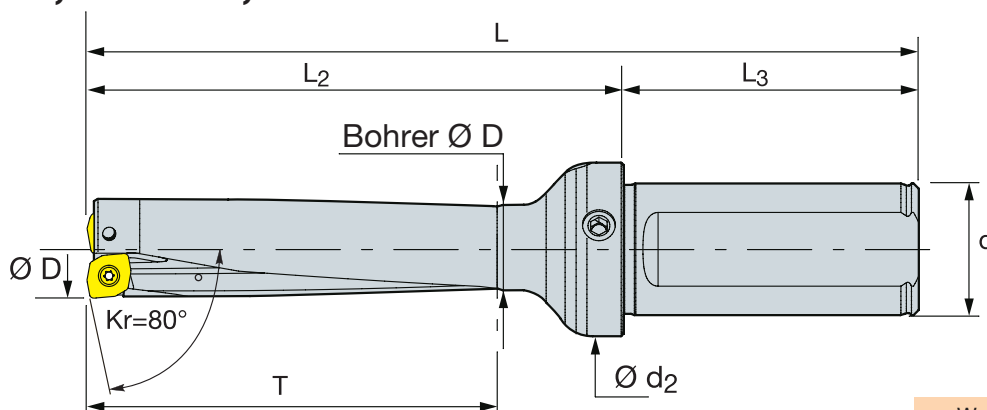

Warengruppe 06H

Bestellnummer	Abmessungen in mm								Bohreinsätze	Dis
	D	d	d2	L	T	L ₂	L ₃	kg		
VBSD 22,0 08 T44	22,0	25	33	124	44	68	56	0,335	BESD 08...	★
VBSD 22,0 08 T88	22,0	25	33	168	88	112	56	0,390	BESD 08...	★
VBSD 23,0 08 T46	23,0	25	33	125	46	69	56	0,340	BESD 08...	★
VBSD 23,0 08 T92	23,0	25	33	171	92	115	56	0,405	BESD 08...	★
VBSD 24,0 08 T48	24,0	25	33	127	48	71	56	0,355	BESD 08...	★
VBSD 24,0 08 T96	24,0	25	33	175	96	119	56	0,430	BESD 08...	★
VBSD 25,0 08 T50	25,0	25	33	128	50	72	56	0,365	BESD 08...	★
VBSD 25,0 08 T100	25,0	25	33	178	100	122	56	0,450	BESD 08...	★
VBSD 26,0 09 T52	26,0	32	43	139	52	79	60	0,605	BESD 09...	★
VBSD 26,0 09 T104	26,0	32	43	191	104	131	60	0,685	BESD 09...	★
VBSD 27,0 09 T54	27,0	32	43	140	54	80	60	0,615	BESD 09...	★
VBSD 27,0 09 T108	27,0	32	43	194	108	134	60	0,705	BESD 09...	★
VBSD 28,0 09 T56	28,0	32	43	142	56	82	60	0,635	BESD 09...	★
VBSD 28,0 09 T112	28,0	32	43	198	112	138	60	0,745	BESD 09...	★
VBSD 29,0 09 T58	29,0	32	43	143	58	83	60	0,645	BESD 09...	★
VBSD 29,0 09 T116	29,0	32	43	201	116	141	60	0,775	BESD 09...	★
VBSD 30,0 09 T60	30,0	32	43	145	60	85	60	0,670	BESD 09...	★
VBSD 30,0 09 T120	30,0	32	43	205	120	145	60	0,820	BESD 09...	★

Preise ohne Einsatz. Passende Bohreinsätze BESD siehe Seite 06A-11.

Warengruppe 21

Ersatzteile			
22,0 bis 25,0	SCHT 08 M2,5	SDTG 08	
26,0 bis 30,0	SCHT 09 M3x08	SDTG 09	

★ = ab Lager

☆ = kurzfristig lieferbar

□ = auf Anfrage

Technische Informationen Silber-Drill

Silber-Drill

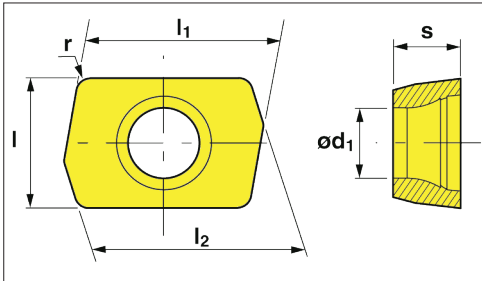

BESD 04
ø12 - 16 mm

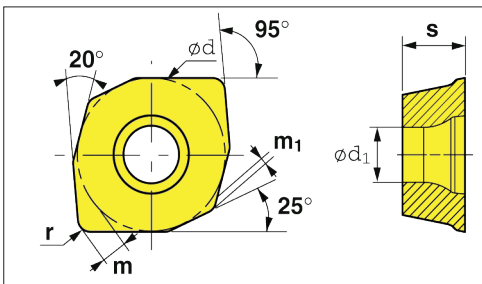

BESD 06/08/09
ø16,5 - 30 mm

Schnittwerte													
Material	Festigkeit Rm (N/mm ²)	Härte	VC (m/min)	Vorschub (mm/U)									
				Ø 12 - 16		Ø 14,5 - 16,0		Ø 16,5 - 21		Ø 22 - 25		Ø 26 - 30	
Stähle				2D	4D	2D	4D	2D	4D	2D	4D	2D	4D
Kohlenstoff < 0.2%	310-580	80-170	180-340										
Kohlenstoff < 0.35%	340-680	90-200	170-320										
Kohlenstoff 0.4%	520-930	150-275	150-300										
Niedriglegiert, gehärtet und vergütet	310-840	80-250	140-290										
Niedriglegiert, gehärtet und vergütet	745-1470	220-450	100-200	0,04- 0,06	0,03- 0,05	0,06- 0,08	0,05- 0,07	0,06- 0,08	0,05- 0,07	0,08- 0,10	0,07- 0,10	0,10- 0,12	0,08- 0,10
Hochlegiert, gegläht	310-840	80-250	110-230										
Hochlegierte Stähle, gehärtet und vergütet	840-1580	250-450	75-150										
Unlegierter Stahlguß	340-760	90-225	125-250										
Niederlegierter Stahlguß	520-745	150-220	110-220										
Hochlegierter Stahlguß	600-775	175-230	90-180										
Rostfreie Stähle													
Geglüht, martensitisch, ferritisch	-	90-225	140-230	0,04- 0,06	0,03- 0,06	0,06- 0,08	0,05- 0,07	0,06- 0,08	0,05- 0,07	0,08- 0,10	0,07- 0,10	0,10- 0,12	0,08- 0,10
Geglüht, austenitisch	-	150-250	80-154										
Guss													
Temperguß	-	110-145	150-250										
Pearlitischer Temperguß	-	150-270	150-210										
Grauguss (FG)	-	150-220	150-320										
Grauguss (FG)	-	220-330	150-210	0,04- 0,06	0,04- 0,07	0,09- 0,12	0,07- 0,10	0,10- 0,15	0,08- 0,12	0,12- 0,18	0,10- 0,15	0,15- 0,25	0,12- 0,18
Kugelgraphitguß GS, ferritisch	-	125-230	140-180										
Kugelgraphitguß GS, perlitisches	-	200-300	100-210										

Silber-Drill Bohreinsätze BESD

Silber-Drill

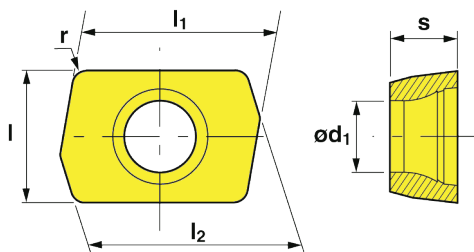

Warengruppe 06I

Bestellnummer	Abmessungen in mm						Vollbohrer	A410
	l	s	d ₁	l ₁	l ₂	r		
BESD 040205	4,6	2,38	2,5	6,682	7,082	0,5	VBSD ... 04 ...	★
Passende Vollbohrer VBSD 04... siehe Produktinformation 06A.								

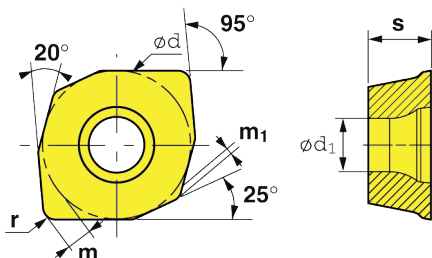

Warengruppe 06I

Bestellnummer	Abmessungen in mm						Vollbohrer	A410
	d	s	d ₁	m	m ₁	r		
BESD 060304	6,35	2,38	2,5	1,308	0,287	0,4	VBSD ... 06 ...	★
BESD 080308	7,94	3,18	2,8	1,338	0,328	0,8	VBSD ... 08 ...	★
BESD 09T308	9,52	3,97	3,4	1,619	0,41	0,8	VBSD ... 09 ...	★
Passende Vollbohrer VBSD 06/08/09... siehe Seite 06A-7 bis 06A-9.								

★ = ab Lager

☆ = kurzfristig lieferbar

□ = auf Anfrage

Gold-Drill

Anwendungsbeispiele

