

Tools for Swiss screw machines

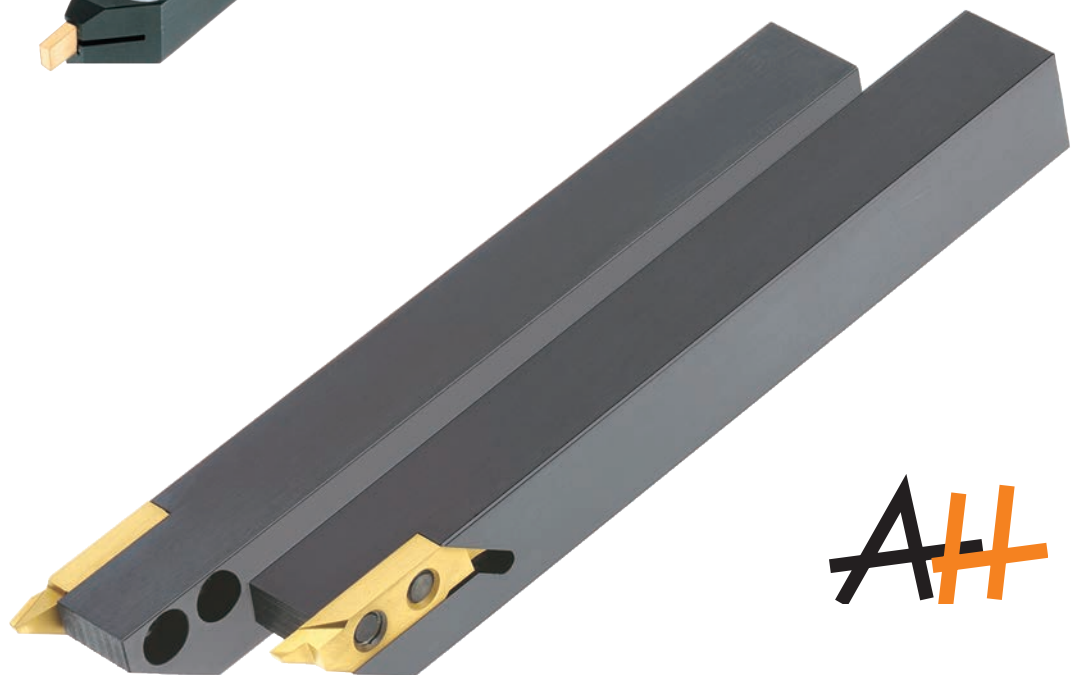

Deco



Tools for Swiss screw machines

Deco holder 05	01E-3
Deco turning blades 05	01E-4
Deco cut-off blades 05	01E-4
Deco holder 08	01E-5
Deco turning blades 08	01E-6
Deco cut-off blades 08	01E-6
Turning tool holder SVJC	01E-7
Turning indexable inserts VC	01E-8
Turning tool holder SDJ	01E-9
Turning indexable inserts DC	01E-10
Longitudinal holder AHLD	01E-11
Inserts for Swiss screw machines AWLD.....	01E-12
Applications longitudinal turning examples.....	01E-13

Other versions and dimensions upon request.
We reserve the right to make technical modifications.
All prices are net in EURO + VAT (value added tax).

Deco holder 05 for Swiss screw machines

Deco

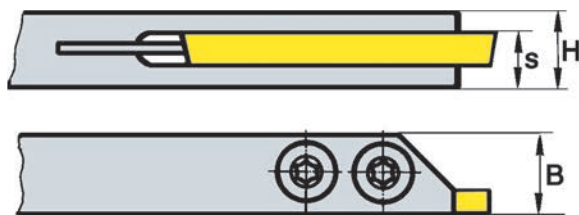

left = L

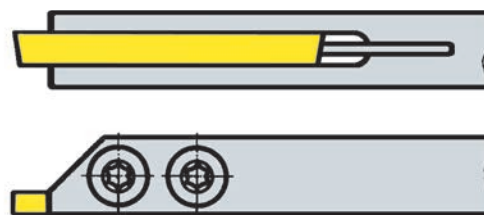

right = R

Product information 01E

Order no.	Dimensions in mm				Dis	Price € / piece
	B	H	L	s		
AH 08 x 08 110 L	8	8	110	6.5	★	96.80
AH 08 x 08 110 R	8	8	110	6.5	★	96.80
AH 10 x 10 120 L	10	10	120	7.5	★	101.60
AH 10 x 10 120 R	10	10	120	7.5	★	101.60
AH 12 x 12 120 L	12	12	120	8.5	★	101.60
AH 12 x 12 120 R	12	12	120	8.5	★	101.60
AH 14 x 14 120 L	14	14	120	10.5	☆	121.00
AH 14 x 14 120 R	14	14	120	10.5	☆	121.00

For compatible blades see page 01E-4.

Product group 21

Spare parts	Screw	€ / piece	Screwdriver flag	€ / piece
for AH 08 x 08	SCHT10 M3 x 7.5	4.90	SDTG 10	9.80
for AH 10 x 10	SCHT20 M4 x 9.5	4.90	SDTG 20	9.80
for AH 12 x 12 / 14 x 14	SCHT25 M5 x 11.5	4.90	SDTG 25	9.80

★ = ex stock

☆ = short lead time

□ = upon request

l ₁ ISO code length	E	F	G	H	J	K	L	M	N	P	Q	R	S	T	X
l ₁ length in mm	70	80	90	100	110	125	140	150	160	170	180	200	250	300	Special

Deco turning blades 05

Deco

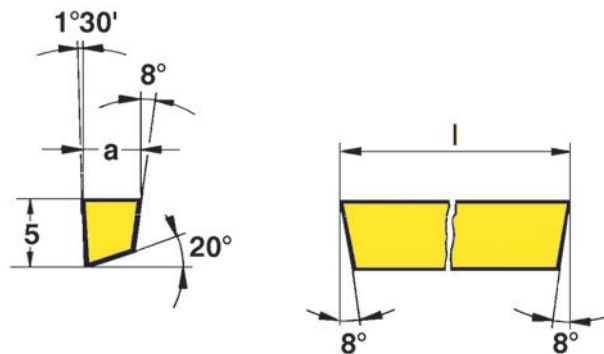

Product information 01F

Order no.	Dimensions in mm		uncoated		Price €/ piece	coated		Price €/ piece
	l	a		K10		A310	A410	
D 2,5	40	2.5		☆	28.00	☆	☆	34.90
D 3,0	40	3.0		☆	28.00	☆	☆	34.90
D 4,0	40	4.0		☆	34.80	☆	☆	41.70

For a compatible holder AH ... see page 01E-3.

Deco cut-off blades 05

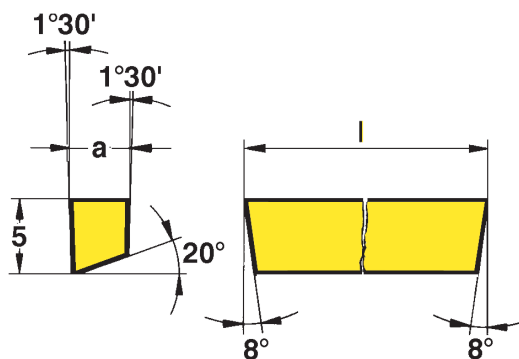

Product information 01F

Order no.	Dimensions in mm		uncoated		Price €/ piece	coated		Price €/ piece
	l	a		K10		A310	A410	
S 1,0	40	1.0		☆	28.00	☆	☆	34.90
S 1,5	40	1.5		☆	28.00	☆	☆	34.90
S 2,0	40	2.0		☆	28.00	☆	☆	34.90
S 2,5	40	2.5		☆	28.00	☆	☆	34.90
S 3,0	40	3.0		☆	28.00	☆	☆	34.90
S 4,0	40	4.0		☆	34.80	☆	☆	41.80

For a compatible holder Deco AH ... see page 01E-3.

★ = ex stock

☆ = short lead time

☐ = upon request

Deco holder 08 for Swiss screw machines

Deco

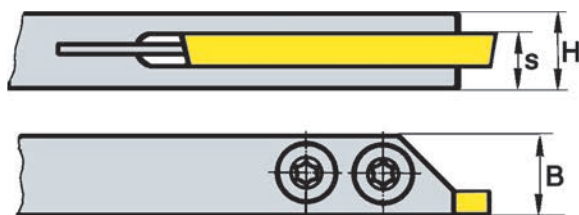

left = L

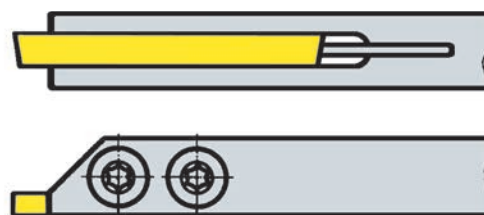

right = R

Product information 01E

Order no.	Dimensions in mm				Dis	Price €/ piece
	B	H	L	s		
AH 16 x 16 140 L 08	16	16	140	12.5	★	121.00
AH 16 x 16 140 R 08	16	16	140	12.5	★	121.00
AH 20 x 20 140 L 08	20	20	140	16.0	★	125.40
AH 20 x 20 140 R 08	20	20	140	16.0	★	125.40

For compatible blades see page 01E-6.

Product group 21

Spare parts	Screw	€/ piece	Screwdriver flag	€/ piece
for AH 16 x 16	SCHT25 M5 x 15	4.90	SDTG 25	9.80
for AH 20 x 20	SCHT30 M6 x 16	4.90	SDTG 30	9.80

★ = ex stock

☆ = short lead time

☐ = upon request

l ₁ ISO code length	E	F	G	H	J	K	L	M	N	P	Q	R	S	T	X
l ₁ length in mm	70	80	90	100	110	125	140	150	160	170	180	200	250	300	Special

Deco turning blades 08

Deco

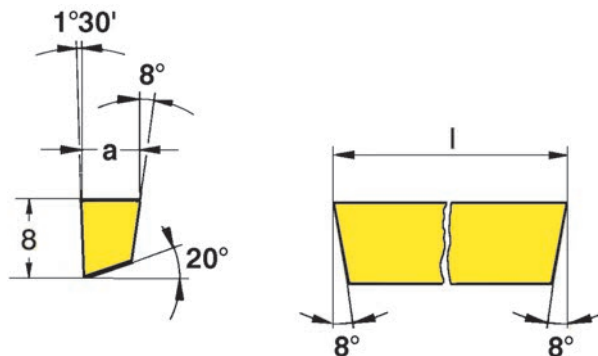

Product information 01F

Order no.	Dimensions in mm		uncoated		Price €/ piece	coated		Price €/ piece
	l	a		K10UF		A310	A410	
D 4,0 08	50	4.0		★	41.50	☆	☆	48.40

For a compatible holder AH ...08 see page 01E-5.

Deco cut-off blades 08

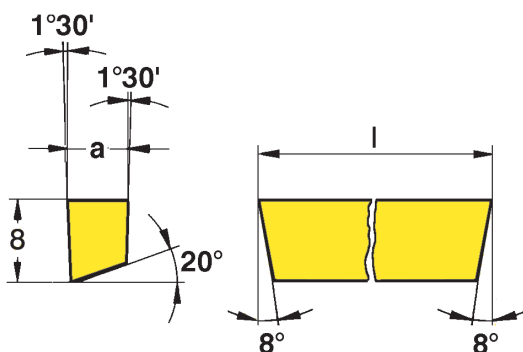

Product information 01F

Order no.	Dimensions in mm		uncoated		Price €/ piece	coated		Price €/ piece
	l	a		K10UF		A310	A410	
S 1,5 08	50	1.5		★	41.50	☆	☆	48.40
S 2,0 08	50	2.0		★	41.50	☆	☆	48.40
S 3,0 08	50	3.0		★	44.20	☆	☆	51.10
S 4,0 08	50	4.0		★	44.20	☆	☆	51.10

For a compatible holder AH ...08 see page 01E-5.

★ = ex stock



☆ = short lead time

☐ = upon request

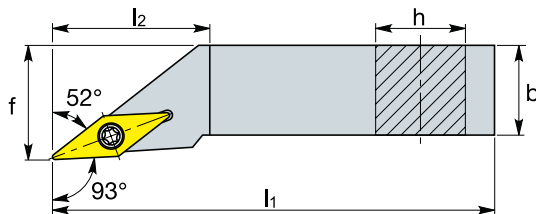
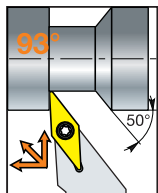
Turning tool holder SVJC ...





Product group 05A

Order no.		Dimensions in mm					Indexable insert	Torx screw	Screwdriver	Price € / piece	Dis		
h	b	l ₁	l ₂	f		L					N	R	
SVJCR /L	12	12	N	13	27	16	VC...13 	SCHT09 M3 x 06 	SDTG 09 	9.80 EUR	<input type="checkbox"/>	<input type="checkbox"/>	<input type="checkbox"/>
SVJCR /L	16	16	H	13	27	20					<input type="checkbox"/>	<input type="checkbox"/>	<input type="checkbox"/>

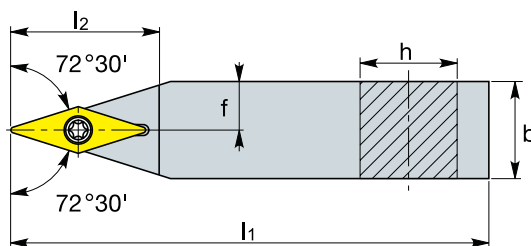
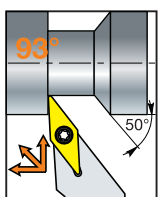
For compatible inserts see page 01E-8.





Product group 05A

Order no.		Dimensions in mm					Indexable insert	Torx screw	Screwdriver	Price € / piece	Dis		
h	b	l ₁	l ₂	f		L					N	R	
SVVCN	12	12	N	13	27	6	VC...13 	SCHT09 M3 x 06 	SDTG 06 	9.80 EUR	<input type="checkbox"/>	<input type="checkbox"/>	<input type="checkbox"/>
SVVCN	16	16	H	13	30	8					<input type="checkbox"/>	<input type="checkbox"/>	<input type="checkbox"/>

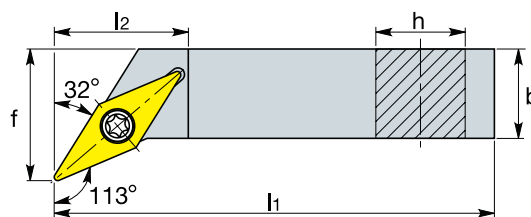
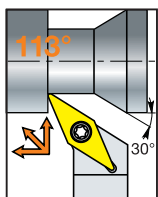
For compatible inserts see page 01E-8.



Product group 05A

Order no.		Dimensions in mm					Indexable insert	Torx screw	Screwdriver	Shim seat	Price € / piece	Dis		
h	b	l ₁	l ₂	f		L						N	R	
SVGCR/L	12	12	M	07	18	12.5	VC...07 	SCHT06 M2 x 03 	SDTG 06 	9.80 EUR	<input type="checkbox"/>	<input type="checkbox"/>	<input type="checkbox"/>	
SVGCR/L	16	16	P	07	23	16.3					<input type="checkbox"/>	<input type="checkbox"/>	<input type="checkbox"/>	

For compatible inserts see page 01E-8.

★ = ex stock

☆ = short lead time

= upon request

l ₁ ISO code length	E	F	G	H	J	K	L	M	N	P	Q	R	S	T	X
l ₁ length in mm	70	80	90	100	110	125	140	150	160	170	180	200	250	300	Special

Turning indexable inserts VC ...

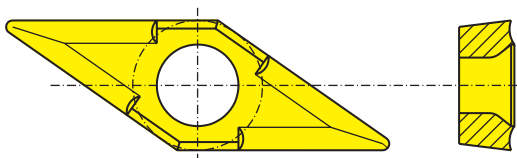

Product group 05B

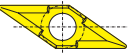
Order no.	Dimensions in mm			Prices are in EURO € / piece											Compatible indexable inserts			
				coated						uncoated								
	l	s	m		A310	A410	A510		K10									
VCGT 130302- 21	13.84	3.18	8.767	<input type="checkbox"/>	<input type="checkbox"/>	<input type="checkbox"/>	<input type="checkbox"/>	<input type="checkbox"/>	<input type="checkbox"/>	<input type="checkbox"/>	<input type="checkbox"/>	<input type="checkbox"/>	<input type="checkbox"/>	<input type="checkbox"/>				
VCGT 130304- 21	13.84	3.18	8.301	<input type="checkbox"/>	<input type="checkbox"/>	<input type="checkbox"/>	<input type="checkbox"/>	<input type="checkbox"/>	<input type="checkbox"/>	<input type="checkbox"/>	<input type="checkbox"/>	<input type="checkbox"/>	<input type="checkbox"/>	<input type="checkbox"/>	-		-	
VCGT 130308- 21	13.84	3.18	7.372	<input type="checkbox"/>	<input type="checkbox"/>	<input type="checkbox"/>	<input type="checkbox"/>	<input type="checkbox"/>	<input type="checkbox"/>	<input type="checkbox"/>	<input type="checkbox"/>	<input type="checkbox"/>	<input type="checkbox"/>	<input type="checkbox"/>				
VCGT 130302- 22	13.84	3.18	8.767	<input type="checkbox"/>	<input type="checkbox"/>	<input type="checkbox"/>	<input type="checkbox"/>	<input type="checkbox"/>	<input type="checkbox"/>	<input type="checkbox"/>	<input type="checkbox"/>	<input type="checkbox"/>	<input type="checkbox"/>	<input type="checkbox"/>				
VCGT 130304- 22	13.84	3.18	8.301	<input type="checkbox"/>	<input type="checkbox"/>	<input type="checkbox"/>	<input type="checkbox"/>	<input type="checkbox"/>	<input type="checkbox"/>	<input type="checkbox"/>	<input type="checkbox"/>	<input type="checkbox"/>	<input type="checkbox"/>	<input type="checkbox"/>	-		-	
VCGT 130308- 22	13.84	3.18	7.372	<input type="checkbox"/>	<input type="checkbox"/>	<input type="checkbox"/>	<input type="checkbox"/>	<input type="checkbox"/>	<input type="checkbox"/>	<input type="checkbox"/>	<input type="checkbox"/>	<input type="checkbox"/>	<input type="checkbox"/>	<input type="checkbox"/>				

For a compatible holder see page 01E-7. Compatible ISO boring bars see production information 02B.

★ = ex stock



☆ = short lead time

= upon request

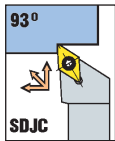
Turning tool holder SDJ ...



Product group 05A

Order no.		Dimensions in mm					Indexable insert	Torx screw	Screwdriver	Dis			Price €/ piece
h	b	l ₁		l ₂	f	L				N	R		
SDJCR/L	10	10	H	07	17	12	VC...07 	SCHT07 M2,2 x 08 	SDTG 07 	<input type="checkbox"/>	<input type="checkbox"/>	<input type="checkbox"/>	
SDJCR/L	12	12	F	07	17	16				<input type="checkbox"/>	<input type="checkbox"/>	<input type="checkbox"/>	
SDJCR/L	16	16	F	07	17	20				<input type="checkbox"/>	<input type="checkbox"/>	<input type="checkbox"/>	
								9.80 EUR					

For compatible inserts see page 01E-10.

★ = ex stock

☆ = short lead time

= upon request

l ₁ ISO code length	E	F	G	H	J	K	L	M	N	P	Q	R	S	T	X
l ₁ length in mm	70	80	90	100	110	125	140	150	160	170	180	200	250	300	Special

Turning indexable inserts DC ...

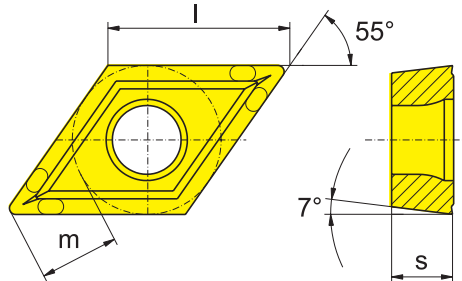

Product group 05B

Order no.	Dimensions in mm			Prices are in EURO € / piece										Compatible indexable inserts	
				coated					uncoated						
	l	s	m		M920	S920				M20	P20				
DCMT 070202 W3 WA	7.7	2.38	3.464	<input type="checkbox"/>						<input type="checkbox"/>					
DCMT 070204 W3 WA	7.7	2.38	3.238	<input type="checkbox"/>		-		-		<input type="checkbox"/>		-		-	
DCMT 070208 W3 WA	7.7	2.38	2.768	<input type="checkbox"/>						<input type="checkbox"/>					

For a compatible holder see page 01E-9. Compatible ISO boring bars see production information 02B.

Product group 05B

Order no.	Dimensions in mm			Prices are in EURO € / piece										Compatible indexable inserts	
				coated					uncoated						
	l	s	m		S415	S425									
DCMT 070202 B3 Y	7.7	2.38	3.464	<input type="checkbox"/>		<input type="checkbox"/>									
DCMT 070204 B3 Y	7.7	2.38	3.238	<input type="checkbox"/>		<input type="checkbox"/>			-		-		-		-
DCMT 070208 B3 Y	7.7	2.38	2.768	<input type="checkbox"/>		<input type="checkbox"/>									

For a compatible holder see page 01E-9. Compatible ISO boring bars see production information 02B.

★ = ex stock





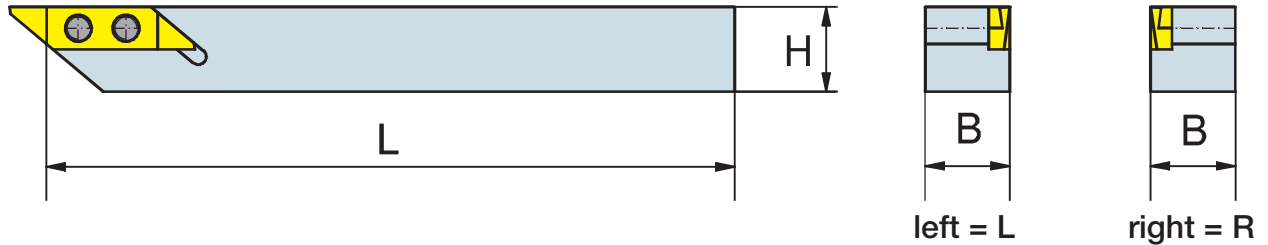

☆ = short lead time

= upon request

Longitudinal holder AHLD



Product group 01M

Order no.					Dimensions in mm			Indexable insert	Screw	Screwdriver flag		Dis			Price €/ piece
H	B	L		H	B	L	L						R		
AHLD	10	10	130	R	10	10	130		SCHT20 M5x9 					☆	65.00
AHLD	12	12	130	R	12	12	130							☆	65.00
AHLD	10	10	130	L	10	10	130					☆			65.00
AHLD	12	12	130	L	12	12	130					☆			65.00
AHLD	16	16	130	R	16	16	130		SCHT20 M5x12 					☆	77.00
AHLD	20	20	130	R	20	20	130							☆	77.00
AHLD	16	16	130	L	16	16	130					☆			77.00
AHLD	20	20	130	L	20	20	130					☐			

For compatible inserts see page 01E-12.

★ = ex stock

☆ = short lead time

☐ = upon request

Inserts for Swiss screw machines AWLD

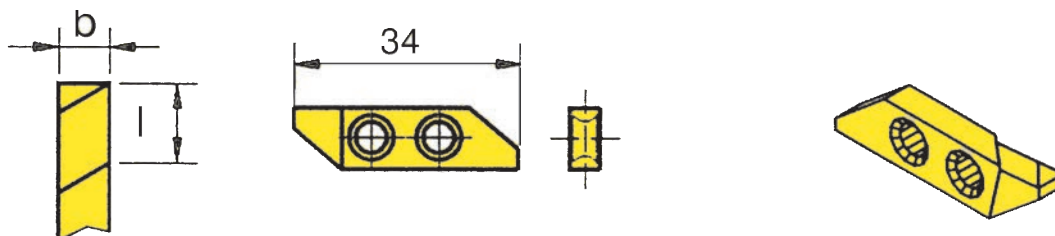

Product group 01N

Order no.	Dimensions in mm			Prices are in EURO € / piece								Compatible indexable inserts		
				coated				uncoated						
	b	l	a	A310	A410			K10F						
Cut-off / turning														
AWLD 1,0 R/L AD	1.0	2.5		☆	28.60	☆	30.30			☆	25.30			
AWLD 1,5 R/L AD	1.5	3.0		☆	26.60	☆	28.30			☆	23.30			
AWLD 2,0 R/L AD	2.0	4.0		☆	26.60	☆	28.30			☆	23.30			
AWLD 2,5 R/L AD	2.5	5.0		☆	26.60	☆	28.30			☆	23.30			
AWLD 3,0 R/L AD	3.0	6.0		☆	26.60	☆	28.30			☆	23.30			
Grooving / turning														
AWLD 3,0-1,6 R/L ED	3.0	3.8	1.6	☆	26.60	☆	28.30			☆	23.30			
AWLD 3,5-1,6 R/L ED	6.8	5.0	1.6	☆	26.60	☆	28.30			☆	23.30			
AWLD 4,0-1,6 R/L ED	4.0	3.8	1.6	☆	26.60	☆	28.30			☆	23.30			
Cut-off operation														
AWLD 1,0 R/L AS	1.0	5.5		☆	23.30	☆	25.20			☆	20.20			
AWLD 1,5 R/L AS	1.5	6.5		☆	23.30	☆	25.20			☆	20.20			
AWLD 2,0 R/L AS	2.0	8.5		☆	23.30	☆	25.20			☆	20.20			
AWLD 2,5 R/L AS	2.5	8.5		☆		☆	25.20			☆	20.20			
Grooving - profile grooving (relieve cut for threads)														
AWLD 1,5 R/L FS	1.5	4.0		☐		☐								
AWLD 2,0 R/L FS	2.0	5.0		☐		☐								
AWLD 2,5 R/L FS	2.5	5.0		☐		☐								
For a compatible holder see page 01E-11. Other forms and profiles upon request.														

★ = ex stock

☆ = short lead time

☐ = upon request

Applications longitudinal turning examples

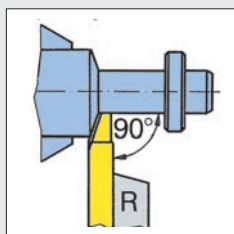

Grooving turning

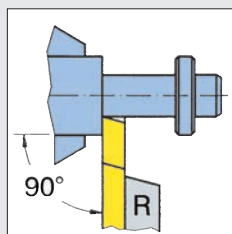

Turning Cut-off operation

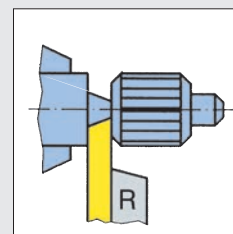

Cut-off operation

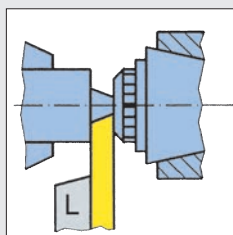

Cut-off operation

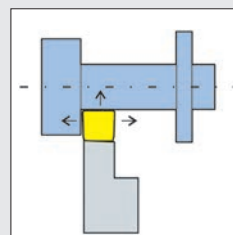

Recessing

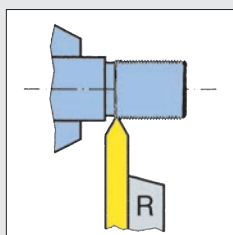

Partial thread

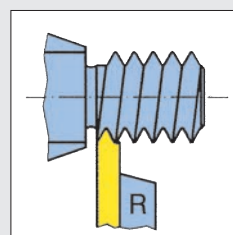

Solid thread

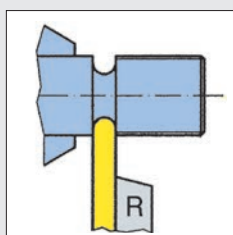

Profile grooving

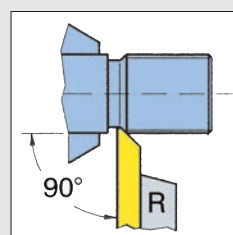

Additional tools: logo

Deco

Fix-Profil

Flat form tools

Longitudinal holder with
indexable inserts
for Swiss screw machines



Quattro

Cut-off blades with 4 edges

Centering and end facing tools



M-System

Cut-off turning on
multi-spindle machines