

Internal grooving tools



Internal grooving tools

Internal boring bar mini IBSM	09A-3
Internal insert mini ISPM	09A-4
Internal insert mini ISPM	09A-5

Other versions and dimensions upon request.
We reserve the right to make technical modifications.
All prices are net in EURO + VAT (value added tax).

Internal boring bar mini IBSM ...

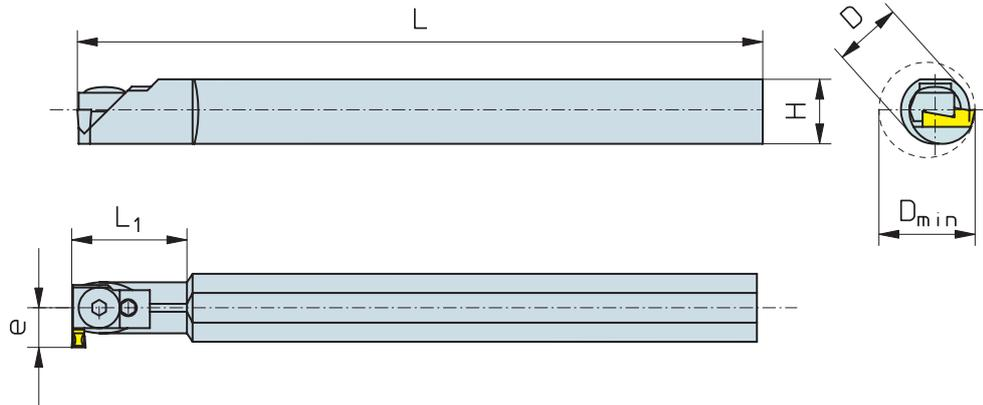

Product group 09A

Order no.	Dimensions in mm				L	L ₁	Dis	
	D _{min}	D	e	H				
IBSM 10 L/ R	10	10	6	9.5	150	20	★	
IBSM 12 L/ R	12	12	7	11.4	150	20	★	
IBSM 16 L/ R	16	16	8	15.3	180	25	★	
IBSM 20 L/ R	18	20	9	19.2	180	25	★	

For compatible internal inserts ISPM ... see page 09A-4 and 09A-5.

Product group 21

Spare parts	Clamp	Screw
Boring bar IBSM10 L/ R	PR- IBSM10L / PR- IBSM10R	SCHT 08 x 7
Boring bar IBSM12 L/ R	PR- IBSM12L / PR- IBSM12R	SCHT 08 x 8
Boring bar IBSM16 L/ R	PR- IBSM16L / PR- IBSM16R	SCHT 08 x 8
Boring bar IBSM20 L/ R	PR- IBSM20L / PR- IBSM20R	SCHT 08 x 8
	Key	
Fits all sizes	SDIW 2,0	

★ = ex stock

☆ = short lead time

□ = upon request

Internal insert mini ISPM ...

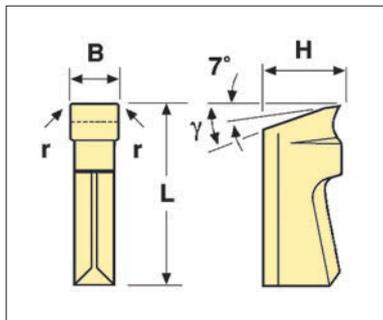

Profile A
Alu

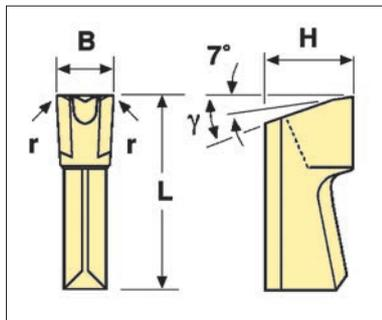

Profile K
Copy

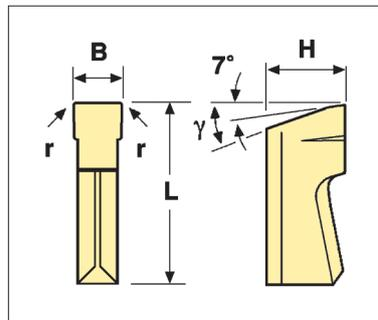

Profile N
Neutral

Product group 09B

Order no.	Dimensions in mm						uncoated		coated	
	B ^{+0.1}	Ø _{min.}	H	L _{-0.1}	r	γ		K10	S360	S630
ISPM2,0 AD10	2.0	10	3.6	9	0.3	30°		★		
ISPM2,5 AD10	2.5	10	3.6	9	0.3	30°		★		
ISPM2,0 AD16	2.0	16	3.6	9	0.3	20°		★		
ISPM2,5 AD16	2.5	16	3.6	9	0.3	20°		★		
ISPM2,0 FD10	2.0	10	3.6	9	0.3	30°		□		
ISPM2,5 FD10	2.5	10	3.6	9	0.3	30°		□		
ISPM2,0 FD16	2.0	16	3.6	9	0.3	20°		□		
ISPM2,5 FD16	2.5	16	3.6	9	0.3	20°		□		
ISPM2,0 KD10	2.0	10	3.6	9	0.3	30°		☆	★	★
ISPM2,5 KD10	2.5	10	3.6	9	0.3	30°		☆	★	★
ISPM2,0 KD16	2.0	16	3.6	9	0.3	20°		☆	★	★
ISPM2,5 KD16	2.5	16	3.6	9	0.3	20°		☆	★	★
ISPM2,0 ND10	2.0	10	3.6	9	0.3	30°		★	★	
ISPM2,5 ND10	2.5	10	3.6	9	0.3	30°		★	★	
ISPM2,0 ND16	2.0	16	3.6	9	0.3	20°		★	★	
ISPM2,5 ND16	2.5	16	3.6	9	0.3	20°		★	★	

Profile F = Special profile upon request.

For compatible internal boring bars Mini IBSM ... see page 09A-3.

★ = ex stock

☆ = short lead time

□ = upon request

Internal insert mini ISPM ...

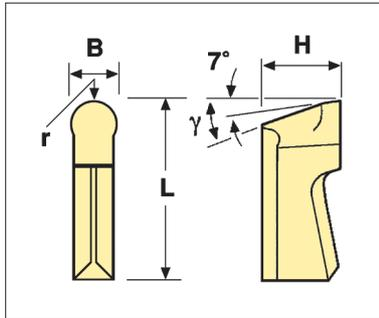

Profile R
Radius

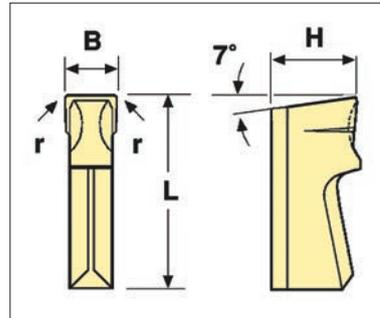

Profile S
Parting

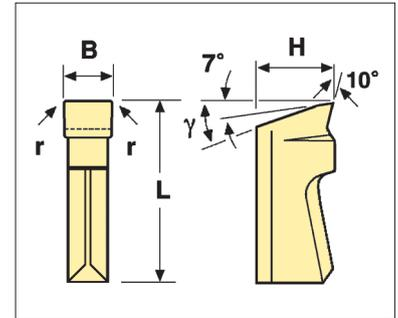

Profile V
V-Materials

Product group 09B

Order no.	Dimensions in mm						uncoated		coated	
	B ± 0.1	$\varnothing_{\min.}$	H	L $_{0.2}$	r	γ		K10	S360	S630
ISPM1,8 RD10	1.8	10	3.6	9	0.90	30°		★	★	★
ISPM2,3 RD10	2.3	10	3.6	9	1.15	30°		★	★	★
ISPM1,8 RD16	1.8	16	3.6	9	0.90	20°		★	★	★
ISPM2,3 RD16	2.3	16	3.6	9	1.15	20°		★	★	★

For compatible internal boring bars Mini IBSM ... see page 09A-3.

Product group 09B

Order no.	Dimensions in mm						uncoated		coated	
	B ± 0.1	$\varnothing_{\min.}$	H	L $_{0.1}$	r	γ		K10	S360	S630
ISPM2,0 SD16	2.0	16	3.6	9	0.3	20°		★		★
ISPM2,5 SD16	2.5	16	3.6	9	0.3	20°		★		★
ISPM2,0 VD10	2.0	10	3.6	9	0.3	30°		★	★	★
ISPM2,5 VD10	2.5	10	3.6	9	0.3	30°		★	★	★
ISPM2,0 VD16	2.0	16	3.6	9	0.3	20°		★	★	★
ISPM2,5 VD16	2.5	16	3.6	9	0.3	20°		★	★	★

For compatible internal boring bars Mini IBSM ... see page 09A-3.

★ = ex stock

☆ = short lead time

□ = upon request

